

MONRA MRF-60

FELLER HEADER



The **MONRA MRF-60** Feller Header is characterized by its great performance and capacity. The use of high quality material in its manufacture ensures its extreme robustness and reliability.

It is designed to easily and safely perform highly demanding and continuous work.

It is suitable for cutting down any kind of tree.

It works on any kind of base machine on the market that is 20 tons or more.

CHARACTERISTICS

Feller Header Shears with a tree gathering system.

Cutting Capacity: 650 mm.

Treated Cutting Blades.

High elastic limit Steel Chassis.

Tilting: -20° , $+20^{\circ}$.

Parker Hydraulic Distributor.

Maximum Work Pressure: 300 kg/cm².

Recommended Base Machine:
20 tons and above.

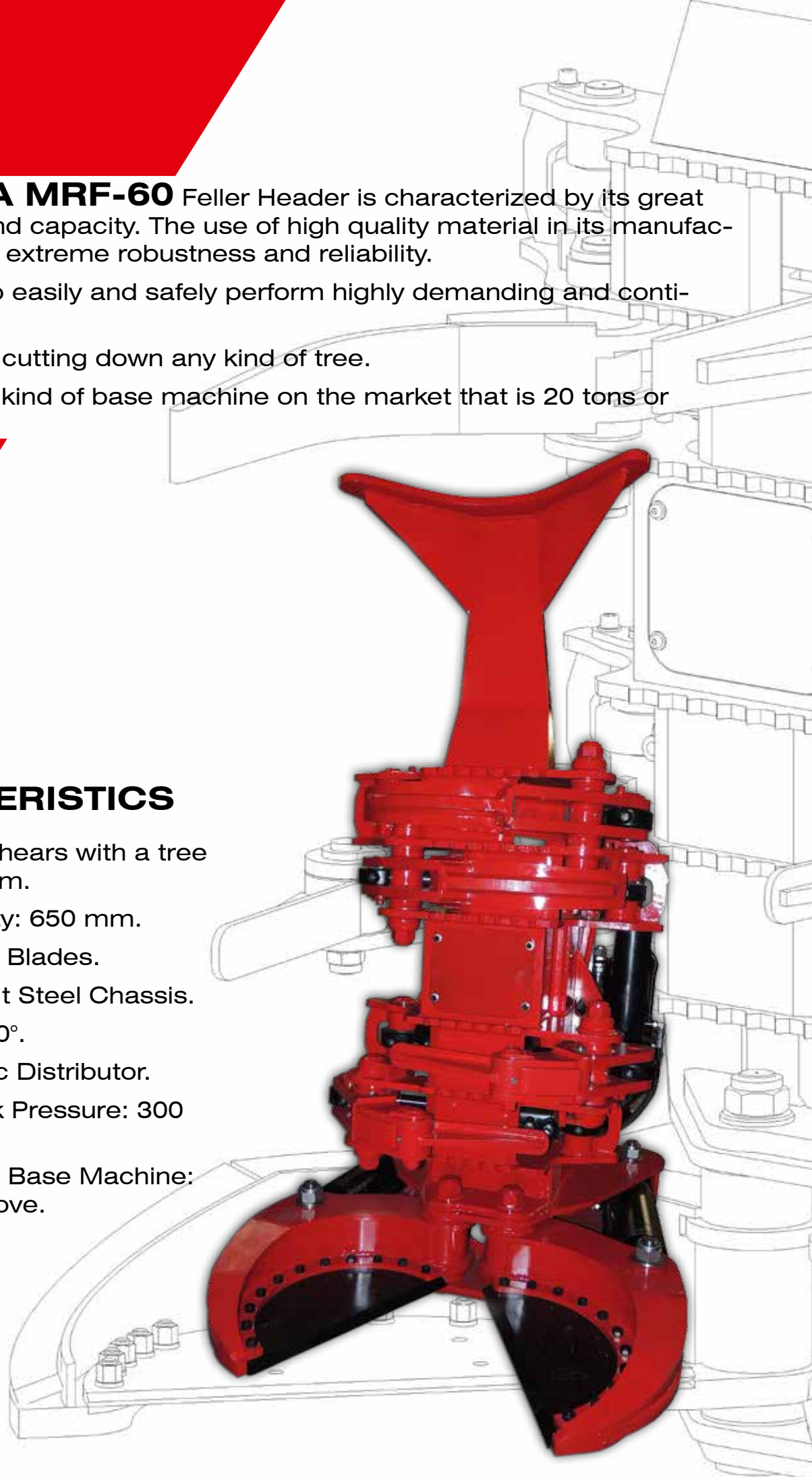

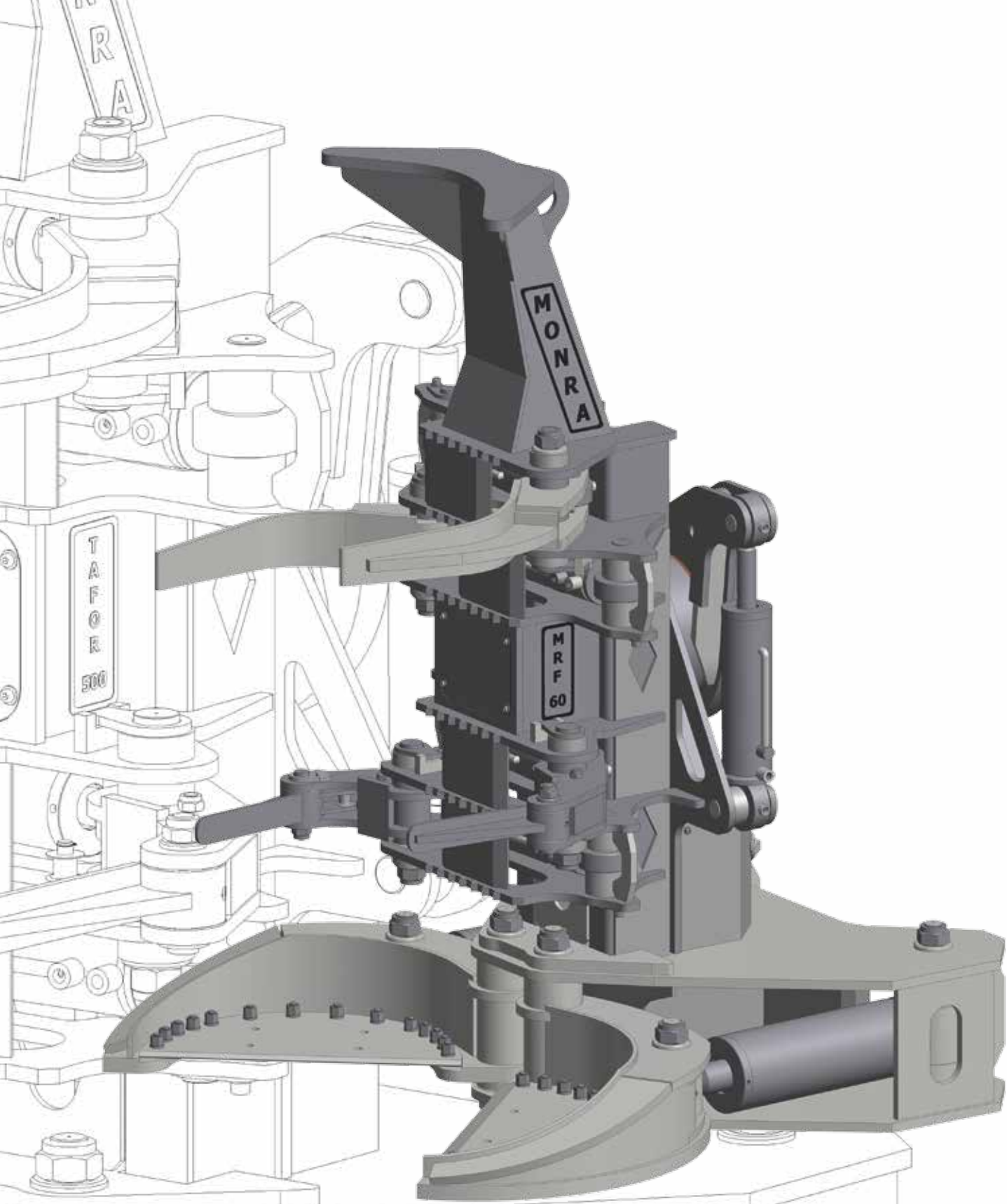

DIMENSIONS

Height:	2564 mm.
Length:	2120 mm.
Width:	1490 mm.

Our company operates under the strict ISO 9001 Quality Control system. This means we are obliged to follow the strictest standards of quality throughout the entire manufacturing process.



ISO 9001

LL-C (Certification)

For each Feller Header:

- Our technical office designs and calculates all the components
- Every aspect of the welding is handled by highly qualified and certified personnel.
- We use only high precision CNC machinery in our work.
- The entire product is examined for approval when finished.



**TALLERES
RAMÓN CASTRO S. L.**
33794 Barres (Castropol)
ASTURIAS (España)
Tlfno: +34 985 62 40 30
e-mail: info@monraforestal.com
web: www.monraforestal.com

TALLERES RAMÓN CASTRO reserves the right to modify the specifications or design without prior notice.